

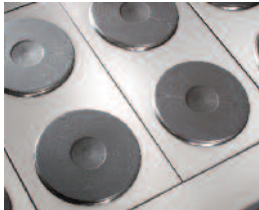

HEAVY DUTY RANGES ROUND PLATE ELEMENTS and GRIDDLE TOP COMBINATIONS

IMPERIAL®

Model Numbers
IHR-GT24-2-E
IHR-GT24-2-E-C
IHR-GT24-2-E-XB
IHR-GT24-2-E-M



9" (229 mm) sealed round plate elements with easy to clean flat surface.



Thick steel polished griddle plate for even heating across the entire surface.



5.3 KW element provides even heating throughout the oven cavity.

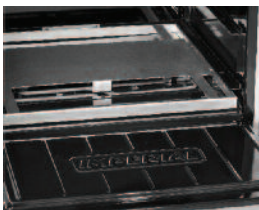

Splatter screen protects the element from spills.



IHR-GT24-2-E shown with optional SHS-36 shelf and casters

ROUND PLATE ELEMENTS - 2 KW round plate elements with easy-to-clean flat surface.

- Provides a solid flat surface for fast, even heating.
- Plates are 9" (229 mm) diameter for maximum pan contact.
- Solid top prevents spills from entering unit making clean-up easy.
- Infinite heat controls for maximum cooking flexibility.

GRIDDLE TOPS - Highly polished griddle plate provide even heat across entire surface.

- 4 KW serpentine elements located under entire griddle plate.
- Thermostat maintains selected temperature during peak hours.
- 4" (102 mm) wide grease gutter and large grease can with 1 gallon (3.8 L) capacity.

STANDARD OVEN - High performance 5.3 KW element provides even heating throughout the oven interior.

- Unique baffle above the element distributes heat flow to provide even cooking temperatures throughout the oven. Splatter screen protects the element from spills.
- Chef depth standard oven interior accommodates standard 18" x 26" (457 x 660 mm) sheet pans front-to-back and side-by side.
- Oven is 26½" w x 26" d x 14" h (673 x 660 x 356 mm).
- Heavy duty thermostat with temperature range from 150°F to 500°F (65°C to 260°C).
- Porcelainized sides, rear, deck and door lining.
- Stamped inner door liner provides extra strength while optimizing heat retention.
- One chrome oven rack is included.

CONVECTION OVEN - 5.3 KW convection oven with 1/4 hp blower motor cooks products quickly and evenly with less shrinkage.

- Convection oven interior dimensions 26-1/2" w x 22-1/2" d x 14" h (673 x 572 x 356 mm).
- Three position switch for cooking or cool down. Fan shuts off automatically when door is open.
- Porcelainized sides, rear, deck and door lining for easy cleaning.
- Three chrome oven racks included.





HEAVY DUTY RANGES ROUND PLATE ELEMENTS and GRIDDLE TOP COMBINATIONS

IMPERIAL®

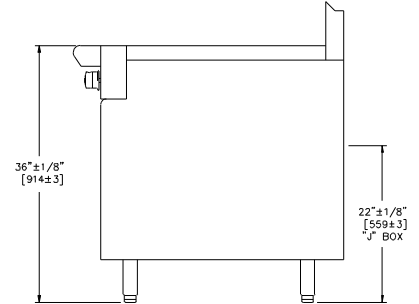
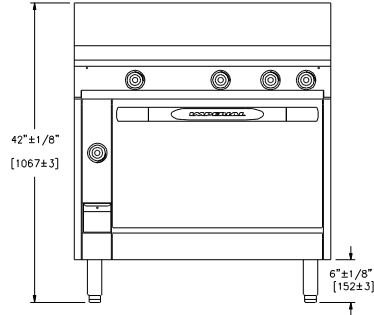
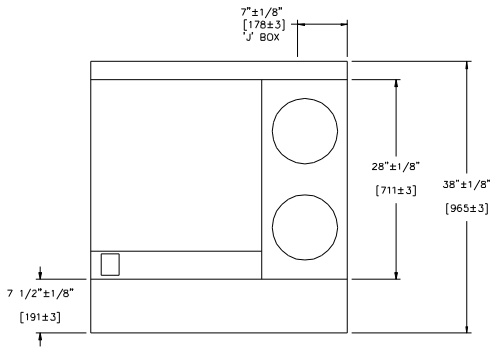

ELECTRIC ROUND PLATE ELEMENTS and GRIDDLE TOP RANGES

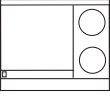
TOP	MODEL	RANGE DEPTH	RANGE WIDTH	SHIP WEIGHT (KW)	LBS
	IHR-GT24-2-E	38"	36"	(293)	646
	IHR-GT24-2-E-C	38"	36"	(320)	706
	IHR-GT24-2-E-XB	38"	36"	(216)	476
	IHR-GT24-2-E-M	38"	36"	(168)	371

Measurements in () are metric equivalents

NOTES

- "C" specifies (1) 26-1/2" (673 mm) Convection Oven
- "XB" specifies (1) Cabinet Base
- "M" specifies Modular, Counter Top Model

EXTERIOR

- Sleek European styling with wide radius ledge and optional high shelf
- Stainless steel front, sides, backguard, shelf, landing ledge and kick plate
- Welded and polished stainless steel seams
- Common ledges, backguards and shelves are available as options for a seamless, professional look
- Large 7" (178 mm) stainless steel landing ledge
- Unique cast aluminum control knobs feature a heat protection grip
- 6" (152 mm) high 2-1/2" (64 mm) diameter heavy duty legs with adjustable feet
- One year parts and labor warranty

DIMENSIONS

36" w x 38" d x 36" h*
(914 x 965 x 914 mm)

* to cooktop

CRATED DIMENSIONS

38-1/2" w x 41" d x 35" h
(978 x 1041 x 889 mm)

CLEARANCE REQUIREMENTS

For use only on non-combustible floors. Legs or casters are required for non-combustible floors; or 2" (51 mm) overhang is required when curb mounted. Provide 0" clearance from non-combustible surfaces and 6" (152 mm) from combustible surfaces.

ELECTRIC HEAVY DUTY RANGES ELECTRICAL REQUIREMENTS

Model	Total KW	Volts	Ph	Amps
IHR-GT24-2-E	17.3	208	1	84
	17.3	208	3	49
	17.3	240	1	73
	17.3	240	3	48
	17.3	480	3	21
IHR-GT24-2-E-C	17.3	208	1	91
	17.3	208	3	56
	17.3	240	1	80
	17.3	240	3	55
	17.3	480	3	28
IHR-GT24-2-E-XB	12	208	1	58
	12	208	3	34
	12	240	1	50
	12	240	3	29
	12	480	3	15
IHR-GT24-2-E-M	12	208	1	58
	12	208	3	34
	12	240	1	50
	12	240	3	29
	12	480	3	15

- Available in 208 and 240 volts, 1 and 3 phase. Please indicate at time of order

OPTIONS AND ACCESSORIES

- Backguards and high shelves
- Extra oven racks
- 6" (152 mm) casters, set of 4, for floor models
- Stainless steel stands for modular models



IMPERIAL®

E-26 5/16

© 2016 Imperial Commercial Cooking Equipment

Printed in the U.S.A.

1128 Sherborn Street Corona, CA 92879
800.343.7790 Ph: 951.281.1830 Fx: 951.281.1879
www.imperialrange.com
E-mail: imperialsales@imperialrange.com