



1/2 SIZE CONVECTION OVENS ELECTRIC TURBO-FLOW

IMPERIAL®

Model Number
HSICVE-1



Turbo-Flow System provides even temperatures throughout the oven cavity.



Oven interior is porcelainized for easy cleaning.



HSICVE-1 shown with optional bottom shelf and casters

TURBO-FLOW SYSTEM - This system assures even cooking throughout the entire oven.

- Creates an air flow that circulates the air throughout all interior surfaces of the oven cavity.
- Recirculates hot air to maximize efficiency for energy savings.
- Fast temperature recovery.
- 1/4 hp fan motor for high production cooking and delicate baking.
- 1-speed oven cool down feature.
- 2 Electrical outputs are available for this model, 5 and 7.5 KW. Please specify when ordering.

OVEN FEATURES - Porcelainized oven interior for easy cleaning and provides better browning.

- Coved oven cavity corners clean easily and quickly.
- Interior oven light is controlled by a momentary switch outside the oven.
- Large window for viewing product at a glance.
- 4 oven racks included with 8 rack guide positions for maximum versatility.
- Easily removable rack guides provide open access for cleaning.

HEAVY DUTY DOOR SYSTEM - Extends the life of the door and eliminates side-to-side shaft movement.

- Bearings on top and bottom of the door.
- Door locking mechanism.
- Door chassis is fortified to withstand constant opening and closing.
- Handle is secured to an internal stainless steel chassis system, not to the external door finish.

EXTERIOR FEATURES - Stainless steel sides, top and legs are standard.

- Manual and programmable control panels are available.





1/2 SIZED CONVECTION OVENS ELECTRIC TURBO-FLOW

IMPERIAL®

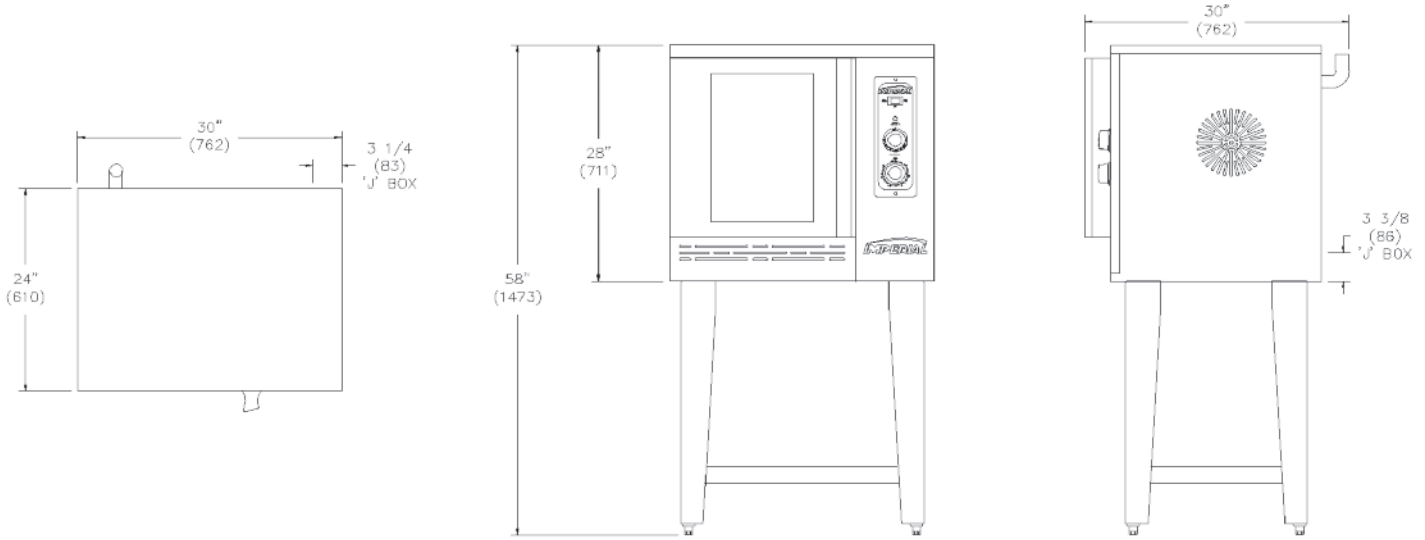

MODEL	DESCRIPTION	TOTAL OUTPUT		SHIP WEIGHT	
		KW	(KG)	(LBS)	
HSICVE-1	1/2 size Single Oven	5	(135)	297	
HSICVE-1	1/2 size Single Oven	7.5	(135)	297	

Measurements in () are metric equivalents.

TOTAL KW	ELECTRICAL REQUIREMENT PER OVEN			
	VOLTS	PHASE	HERTZ	AMPS
5	208	1	50/60	32 per oven
5	208	3	50/60	21 per oven
5	240	1	50/60	28 per oven
5	240	3	50/60	20 per oven
5	480*	3	50/60	14 per oven
7.5	208	1	50/60	44 per oven
7.5	208	3	50/60	28 per oven
7.5	240	1	50/60	39 per oven
7.5	240	3	50/60	26 per oven
7.5	480*	3	50/60	17 per oven

MODEL	DIMENSIONS	CRATED DIMENSIONS
HSICVE-1	30" w x 30" d x 58" h (762 x 762 x 1473 mm)	32" w x 32" d x 32" h (813 x 813 x 813 mm)

EXTERIOR

- Stainless steel exterior, except back. Reflects a quality, professional look for exhibition cooking
- Welded and finished seams
- Stainless steel legs
- Easy to clean and maintain
- One year parts and labor warranty

CLEARANCE REQUIREMENTS

For use only on non-combustible floors with legs or casters; or 2 1/4" (57 mm) overhang is required when curb mounted. 0" clearance from non-combustible side and rear walls. Provide 6" (152 mm) minimum clearance from combustible side walls and 0" from combustible wall at rear.



Manual Controls

- Manual controls are standard
- Independent time and temperature controls provide maximum versatility for general baking and roasting
- 1-speed fan switch

Thermostatic oven control

- Snap Action temperature control 150° F to 550° F. (66° C to 260° C)

On-Off switch Timer

- 60 minute manual timer
- Audible buzzer lets you know when the cooking cycle is complete

Programmable Controls available as an option

OPTIONS AND ACCESSORIES

- Cook and Hold Feature
- Heavy Duty Casters, set of 4
- Stainless Steel bottom shelf only
- Stainless Steel Bottom Shelf and Adjustable Rack Supports
- Stainless Steel solid door, must specify at ordering
- Extra Racks
- 480 volts



IMPERIAL®

E-21

7/16

© 2016 Imperial Commercial Cooking Equipment

Printed in the U.S.A.

1128 Sherborn Street Corona, CA 92879
800.343.7790 Ph: 951.281.1830 Fx: 951.281.1879
www.imperialrange.com
E-mail: imperialsales@imperialrange.com